

OPERATOR'S MANUAL

LP2100-X

INCLUDING: SPECIFICATIONS, SERVICE KITS, PLACING INTO SERVICE, TROUBLESHOOTING
INCLUDE MANUAL: LM2203A-X-B (97999-812), S-633 GENERAL INFORMATION (97999-625)

RELEASED: 12-2-96
REVISED: 2-18-00
(REV. C)



LP2100-1, -2 GEAR OIL PUMP SYSTEMS

SPECIFICATIONS

Model Series	LP2100-1, -2
Type	Air Operated, 16 gal. Gear Oil Pump System
Ratio	3:1
Air Motor Diameter	2" (5.08 cm)
Stroke (Double acting)	3" (7.62 cm)
Air Inlet	1/4 - 18 N.P.T.F. (f)
Material Outlet	1/2 - 14 N.P.T.F. (f)
Pump Construction	Carbon Steel
Dimensional Data "A" (w/o 67086)	43" (1092 mm)
Weight	33.9 lbs (15.4 kg)

PERFORMANCE

Air Inlet Pressure Range	0 - 125 p.s.i. (0 - 8.6 bar)
Fluid Pressure Range	0 - 375 p.s.i. (0 - 25.9 bar)
Displacement In ³ Per Cycle	6.2
Cycles Per Gallon (Liter)	37 (9.8)
Maximum Working Flow Rate	6 g.p.m. (23 l.p.m.)
Maximum Flow Rate	9 g.p.m. (34 l.p.m.)
Noise Level @ 100 psi -124 c/m	80 db(A)

SERVICE KITS

- Use only genuine ARO® replacement parts to assure compatible pressure rating and longest service life.
- **637224 Pump Rebuild Kit.** Includes the necessary soft parts for normal service of the entire pump.

GENERAL DESCRIPTION

LP2100-X Portable Gear Oil Dispensing System. Includes a 3:1 pump, flow meter, drum cover, dolly, material hose and nozzle.

IMPORTANT

This is one of three documents which support the pump system. Replacement copies of these forms are available upon request.

- LP2100-X MODEL OPERATOR'S MANUAL
- LM2203A-X-B MODEL OPERATOR'S MANUAL
- S-633 GENERAL INFORMATION LUBRICATION SYSTEMS

OPERATING AND SAFETY PRECAUTIONS

⚠ WARNING READ THE GENERAL INFORMATION MANUAL INCLUDED FOR OPERATING AND SAFETY PRECAUTIONS AND OTHER IMPORTANT INFORMATION.

PUMP DATA

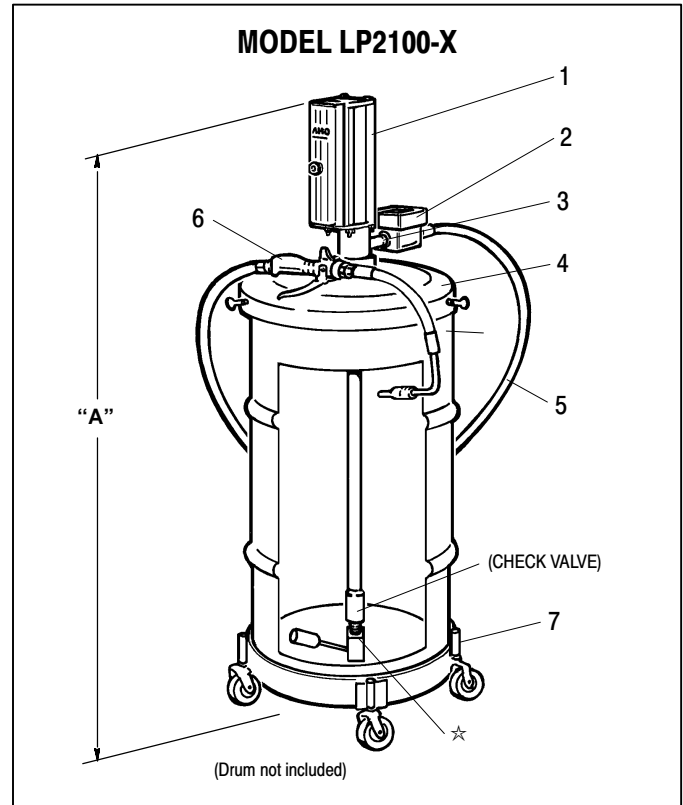

MAJOR COMPONENTS

Item	Description (Size in inches)	(Qty)	Part No.
1	Basic 3:1 Oil Pump	(1)	LM2203A-31-B
2	Digital Meter (Pint) (LP2100-1)	(1)	635190-1
	(Liter) (LP2100-2)	(1)	635190-3
3	Nipple (1/2 - 14 N.P.T. x 2")	(1)	Y44-31-C
4	Cover & Hardware	(1)	94421
5	6' Material Hose (1/2" i.d.)	(1)	623501-6
6	Control Handle	(1)	635391-1
7	Dolly Assembly	(1)	640058-2
☆	Shut-Off Assembly (Optional accessory)	(1)	67086



INGERSOLL-RAND COMPANY
P.O. BOX 151 • ONE ARO CENTER • BRYAN, OHIO 43506-0151
☎ (419) 636-4242 • FAX (419) 633-1674 ©2000 • PRINTED IN U.S.A.

INGERSOLL-RAND
FLUID PRODUCTS

PLACING INTO SERVICE

OPERATING AND SAFETY PRECAUTIONS

⚠️WARNING READ THE GENERAL INFORMATION MANUAL INCLUDED FOR OPERATING AND SAFETY PRECAUTIONS AND OTHER IMPORTANT INFORMATION.

⚠️WARNING EXCESSIVE INLET AIR PRESSURE. Can cause explosion resulting in severe injury or death.

- Do not exceed maximum operating pressure of 375 p.s.i. (25.9 bar) at 125 p.s.i. (8.6 bar) inlet air pressure.
- Do not run pump without using a regulator to limit air supply pressure to the pump.

PUMP RATIO X $\text{INLET PRESSURE TO PUMP MOTOR} = \text{MAXIMUM PUMP}$ FLUID PRESSURE <p>Pump ratio is an expression of the relationship between the pump motor area and the lower pump end area. EXAMPLE: When 125 p.s.i. (8.6 bar) inlet pressure is supplied to the motor of a 3:1 ratio pump it will develop a maximum of 375 p.s.i. (25.9 bar) fluid pressure (at no flow) - as the fluid control is opened, the flow rate will increase as the motor cycle rate increases to keep up with the demand.</p>

⚠️WARNING EXCESSIVE MATERIAL PRESSURE. Can cause equipment failure resulting in severe injury or property damage.

- Do not exceed the maximum material pressure handling capability of any component in the system.
Thermal expansion hazard. This can occur when the fluid in the material line is exposed to elevated temperatures. Example: Material line located in a non-insulated roof area can warm due to sunlight. Install a pressure relief valve in the fluid outlet side of the pumping system if this condition could exist.

AIR AND LUBRICATION REQUIREMENTS

Filtered air will help extend the life of the pump, allowing the pump to operate more efficiently and yield longer service life to moving parts and mechanisms.

- Use an air line filter to provide good quality clean and dry air, install it up stream from the air regulator.
- Use an air regulator on the air supply to control the pump cycle rate, install the regulator as close as possible to the pump.
- In most installations lubrication is not required. If the pump needs to have lubrication, install an air line lubricator between the pump and the air regulator and supply it with a good grade of non-detergent oil or other lubricant compatible with Nitrile seals. Set at a rate not to exceed one drop per minute.

INSTALLATION

Assemble components included in the package as shown in figure 1.
NOTE: In rigid plumbing applications, use flexible material and air supply hoses when attaching the pump to prevent damage by vibration.

1. Thread the bung adapter into the pump cover.
2. Thread the down tube into the bottom of the pump.
3. Thread the check valve onto the down tube and insert the pump into the bung and secure the pump with the thumb screws.
4. Install the shut-off assembly (if used) and drum dolly.
5. Install the outlet nipple, meter, material hose and nozzle.
6. Attach a coupler to the air supply hose.
7. Connect the material hose to the pump outlet. Tighten all fittings. Use caution not to overtighten and damage threads.

OPERATION

START-UP

1. Turn the air regulator to "0" pressure setting. Connect the air hose.
2. Prime the pump by cycling slowly, raising the pressure to 20 - 30 p.s.i. Cycle the pump until the test oil and any trapped air has been purged from the system.
3. Close the dispensing device. Allow the pump to build line pressure and stall. Check for any leaks and re-torque fittings if needed. Adjust air pressure upward as required for the application.

NOTICE: If the pump does not prime soon after initial start-up, establish what the problem is to prevent unnecessary damage to the pump plunger.

SHUTDOWN

- Disconnect the air supply from the pump if it is to be inactive for a few hours. Open the dispensing device to relieve line pressure.

SERVICE

Refer to the basic pump manual for service instructions which also covers disassembly and reassembly for installation of the rebuild kit.

TROUBLE SHOOTING

If the pump does not cycle or will not deliver material.

- Be certain to check for non-pump problems including kinked, restrictive or plugged inlet / outlet hose or dispensing device. Depressurize the pump system and clean out any obstructions in the inlet / outlet material lines.
- Check all seals, including track gaskets.